

PARTS LIST

Trunk spoiler

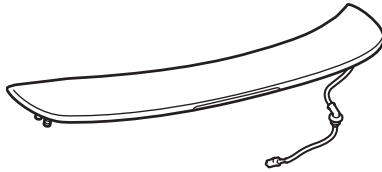

Left trunk spring (marked yellow)

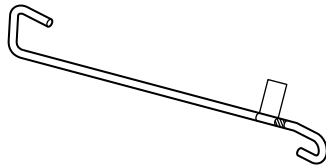

Right trunk spring (marked red)

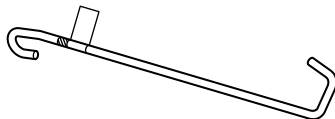

Template

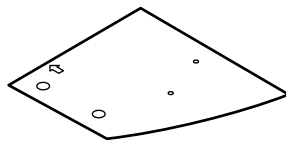

4 Spoiler nuts, 6 mm



4 O-rings



Spoiler harness

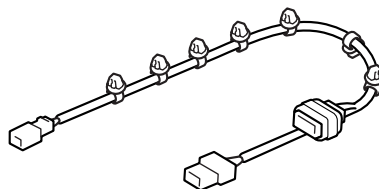

Wire tie

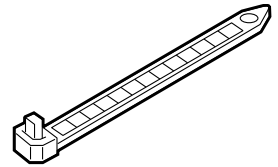

2 Bolts, 6 x 12 mm

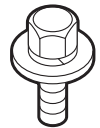

Connector clip



2 EPT sealers

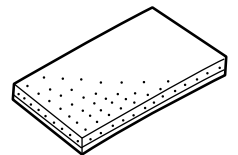

Corrugated tube

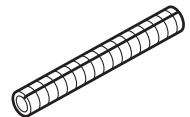

TOOLS AND SUPPLIES REQUIRED

Shop towel
Small flat-tip screwdriver
Eye protection (face shield, safety goggles, etc.)
Drill
3 mm, 8 mm, and 10 mm Drill bits
Drill stop
Felt-tip pen
Center punch
File
Touch-up paint
Socket
Torque wrench
Heavy gloves
Clip remover
Trunk Spring Tool
T/N 07XAZ-S0K-0100 or 07AAF-SNA-A100
Isopropyl alcohol
Silicone spray
Electrical tape

INSTALLATION

Customer Information: The information in this installation instruction is intended for use only by skilled technicians who have the proper tools, equipment, and training to correctly and safely add equipment to your vehicle. These procedures should not be attempted by “do-it-yourselfers.”

NOTE:

- Be careful not to damage the body paint finish.
- This trunk spoiler kit should be installed only if the ambient air temperature is 60°F (15°C) or above.
- Wash and wax the area to be covered. Use a high-quality paste wax.

Installing the Trunk Spoiler

1. Make sure you have the anti-theft codes for the radio and navigation system (if equipped), then write down the radio station presets.
2. Disconnect the negative cable from the battery.

3. On the inside of the trunk lid, locate the two identification marks on the trunk lid. Lightly center-punch each mark. Repeat on the right side of the trunk lid.

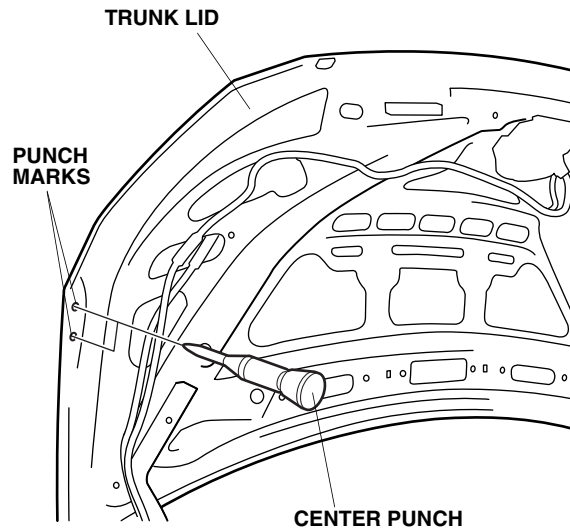

4. While wearing eye protection, first drill the hole with a 3 mm drill bit, and finish with an 8 mm drill bit.
 - To prevent drilling through the trunk lid, wrap a drill stop around the drill bit 10 mm away from the tip.
 - To prevent the metal shavings from falling onto the trunk floor, place a cover onto the trunk floor.
 - Remove all burrs and metal shavings with a file, and apply touch-up paint to the edges of the holes you drilled.
 - Repeat on the right side of the trunk lid.

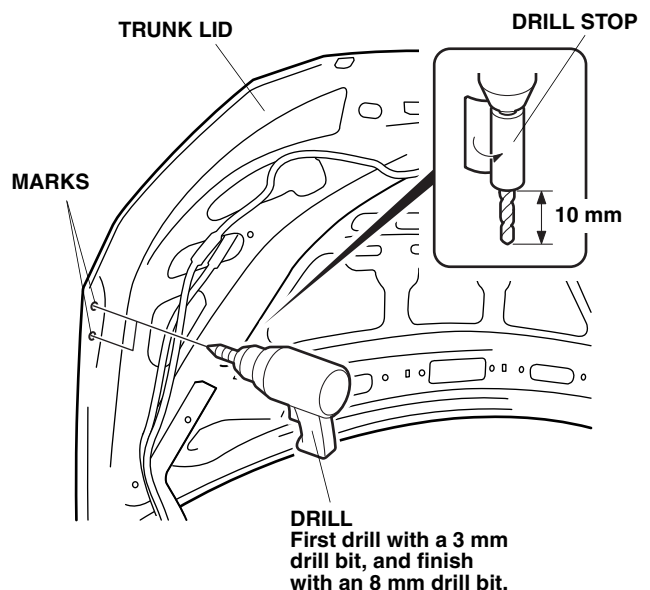

5. Close the trunk lid. Attach tape to the trunk lid as shown.

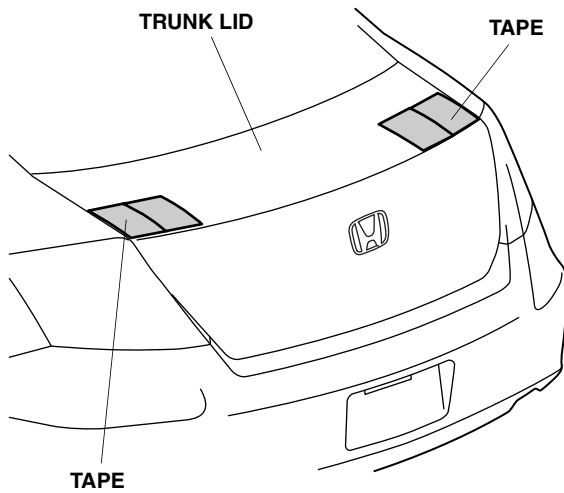

6. Align the template with the left side trunk lid. Using a felt-tip pen, mark the left side trunk lid as shown. Remove the template.

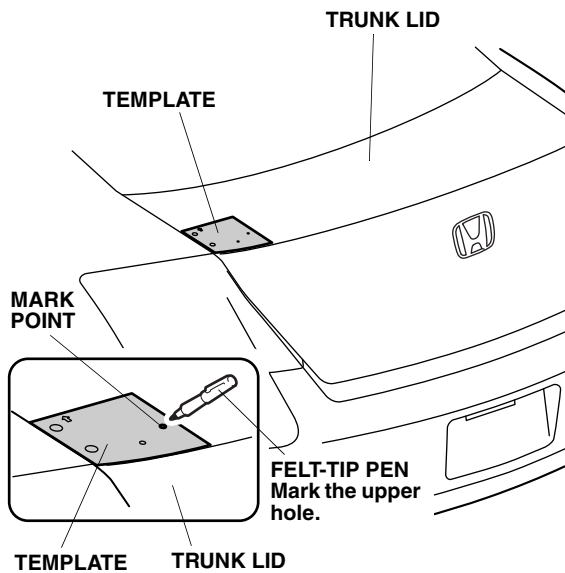

7. Flip the template over. Align the template with the right side trunk lid. Using a felt-tip pen, make two marks on the right side trunk lid as shown. Remove the template.

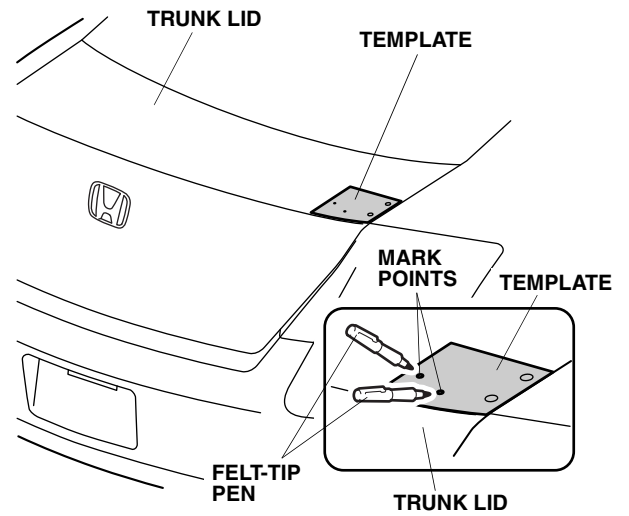

8. Center-punch the mark on the left side trunk lid. While wearing eye protection, first drill the hole with a 3 mm drill bit, and finish with an 8 mm drill bit. Remove the tape.
- To prevent drilling through the trunk lid, wrap a drill stop around the drill bit 10 mm away from the tip.
 - Remove all burrs and metal shavings with a file, and apply touch-up paint to the edges of the holes you drilled.
 - Take care not to damage the wire harnesses when drilling the holes.

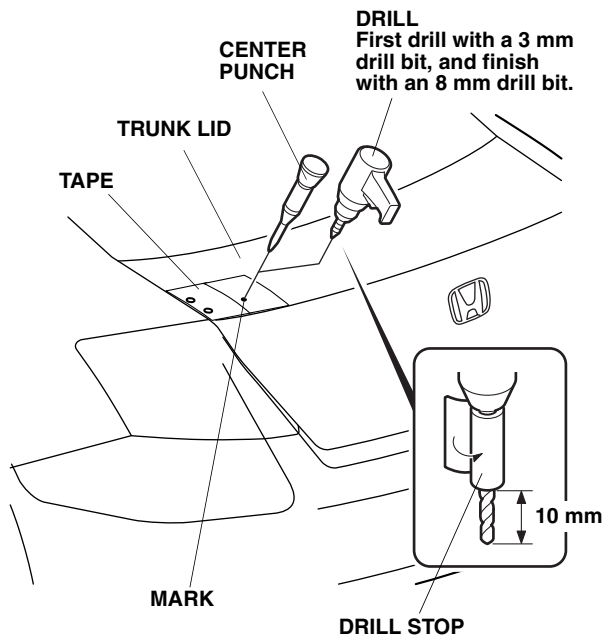

9. Center-punch the two marks on the right side trunk lid.

10. While wearing eye protection, first drill the hole with a 3 mm drill bit, and finish with an 8 mm drill bit to the upper mark.
11. First drill with a 3 mm drill bit, and finish with a 10 mm drill bit to the lower mark. Remove the tape.
- To prevent drilling through the trunk lid, wrap a drill stop around the drill bit 10 mm away from the tip.
 - Remove all burrs and metal shavings with a file, and apply touch-up paint to the edges of the holes you drilled.
 - Take care not to damage the wire harnesses when drilling the holes.

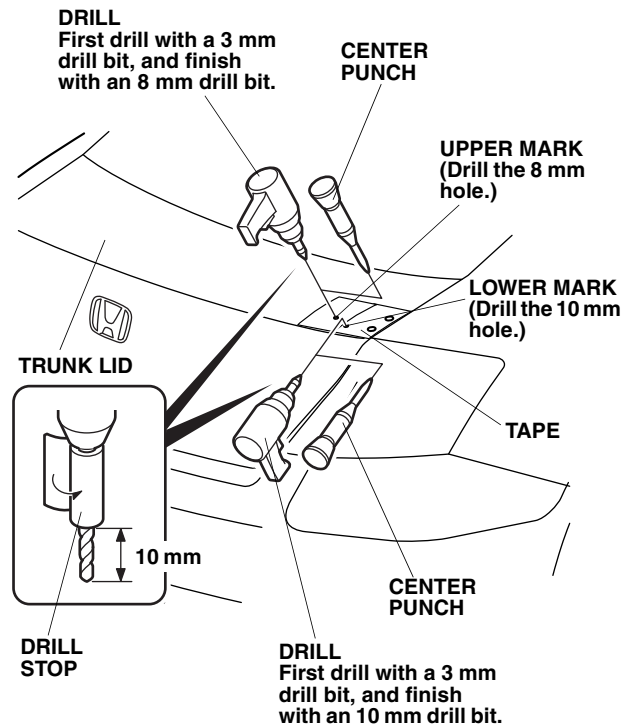

12. Hold the trunk spoiler above the trunk lid, and route the trunk spoiler harness down through the 10 mm hole you drilled. Seat the grommet into the 10 mm hole; then route the trunk spoiler harness through the rectangular hole. If necessary, spray silicone spray on the grommet and use a piece of wire to pull the harness through the trunk lid.

- Fit the trunk spoiler into position on the trunk lid, and install four 6 mm spoiler nuts, four O-rings, and two 6 x 12 mm bolts. Hold the trunk spoiler firmly against the trunk lid and torque the spoiler nuts and bolts to 6 N·m (4.4 lb-ft).

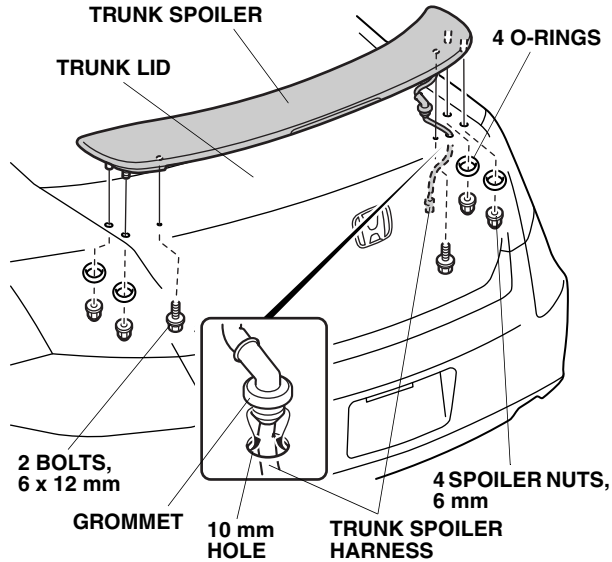

- Position the corrugated tube on the trunk spoiler harness in the position shown. Wrap electrical tape around the corrugated tube to secure.

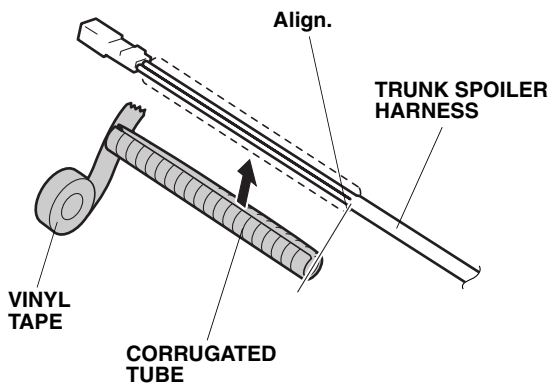

Installing the Trunk Spring

- Push the tab and pull down the seat back release lever to release the hook.
- Slide the seat back release lever to the right side, and remove the release lever from the hole in the vehicle panel.

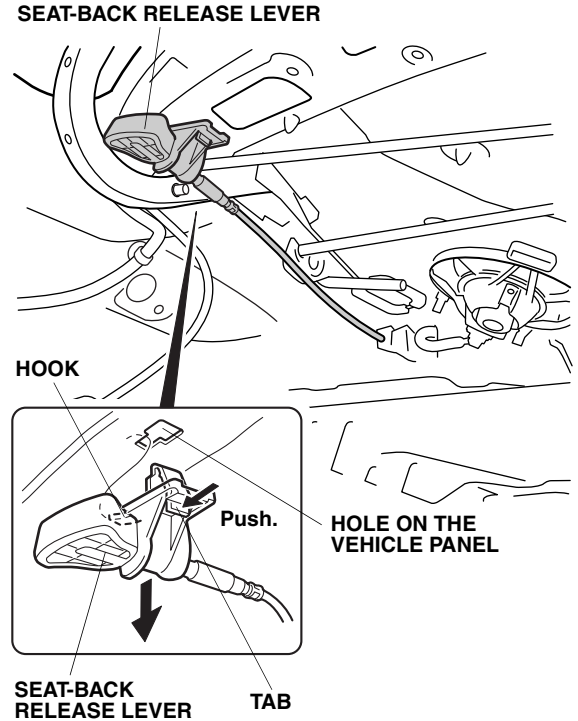

- Open the trunk lid, and remove the center clip from the trunk springs.

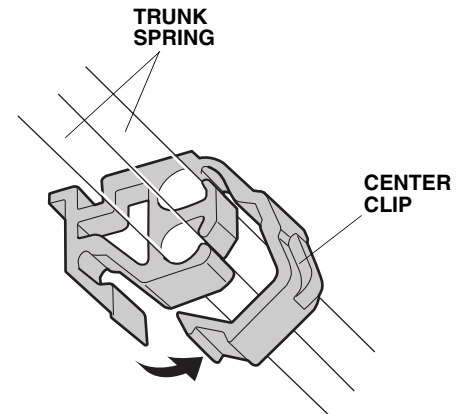

18. With an assistant holding the trunk lid open, remove the old trunk springs from the trunk hinge arms using the trunk spring tool. Wear gloves to protect your hands, and pull the trunk spring tool slowly and carefully toward you.

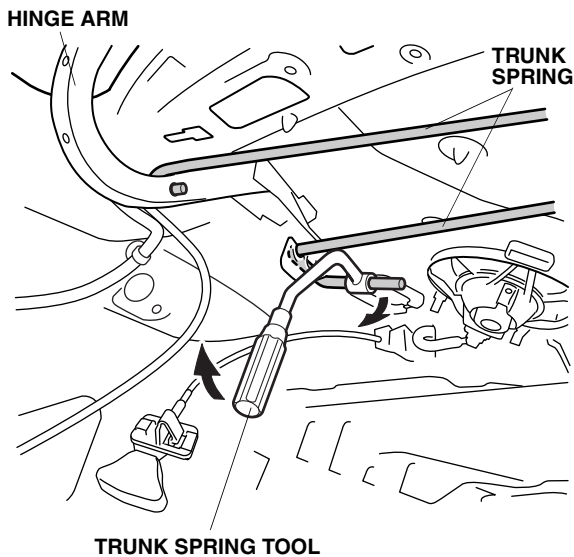

19. Install the right trunk spring and the left trunk spring in the reverse order of removal.

- Set the tool on the marked end of each trunk spring.
- Install the red marked spring in the slot in the right (passenger's) side trunk hinge arm and to the hinge bracket on the left (driver's) side of the car; install the yellow marked spring in the slot in the left (driver's) side trunk hinge arm and to the hinge bracket on the right (passenger's) side of the car.
- Wearing gloves, rotate the tool as you pull it towards you.
- Set the springs in the first notch (original position) of the hinge brackets.

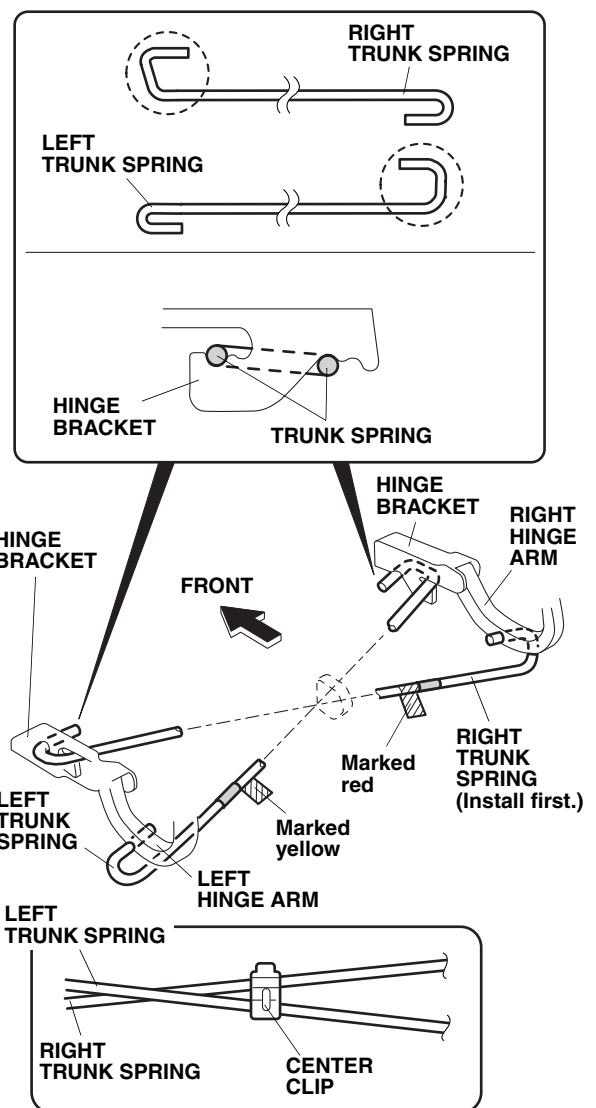

Routing the Spoiler Harness

20. Remove the trunk floor mat (one clip).

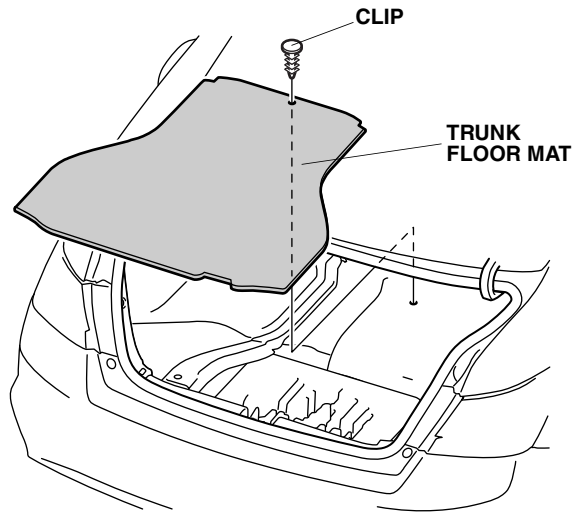

21. Remove the tool box.

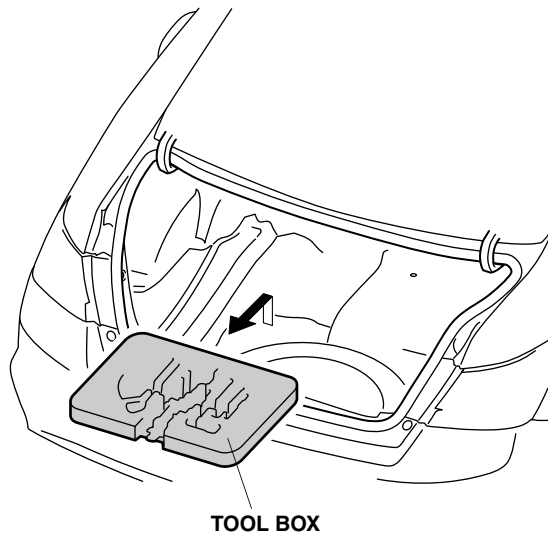

22. Remove the rear trim panel (four clips and three hooks).

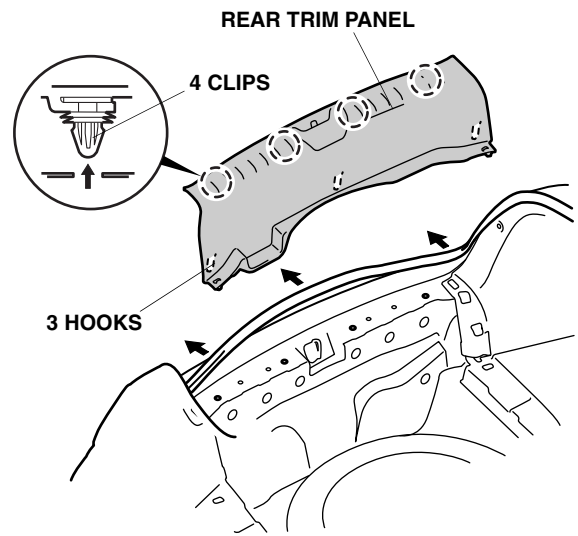

23. Reinstall the seat-back release lever.

24. Inside the trunk, fold the rear seat-back by pulling the lever under the rear parcel shelf.

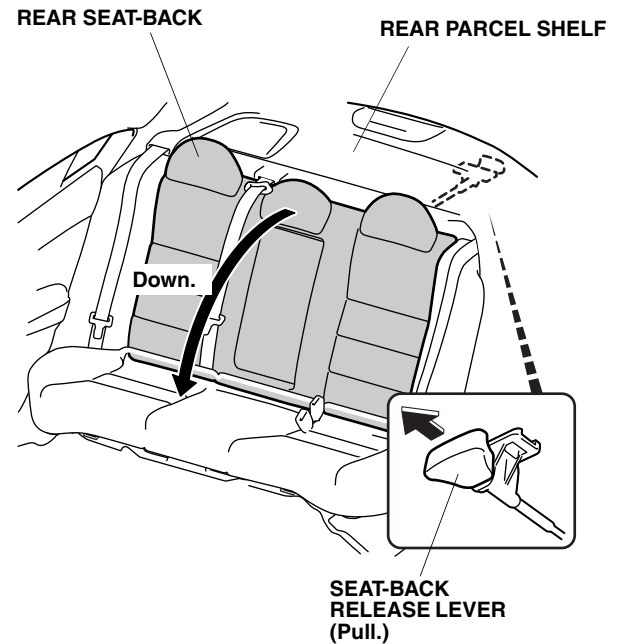

25. Remove the right trunk side lining (five clips).

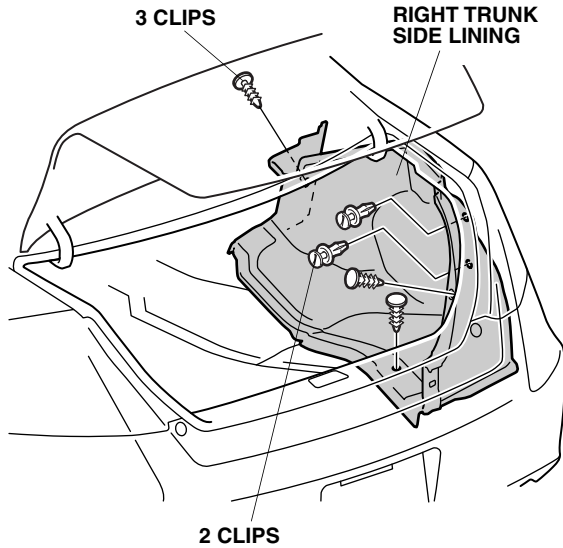

26. Using isopropyl alcohol on a shop towel, clean the trunk lid where the EPT sealer will attach.
27. Route the trunk spoiler harness from the trunk lid hole as shown, and connect the trunk spoiler 2-pin connector to the spoiler harness 2-pin connector.
28. Install the connector clip to the 2-pin connector, and secure the 2-pin connector to the vehicle panel.
29. Cut an EPT sealer in half. Attach one half to the inside of the trunk lid with the trunk spoiler harness as shown.
30. Attach an EPT sealer to the inside of the trunk lid with the spoiler harness as shown.

31. Secure the spoiler harness to the trunk lid with a spoiler harness wire tie with clip.

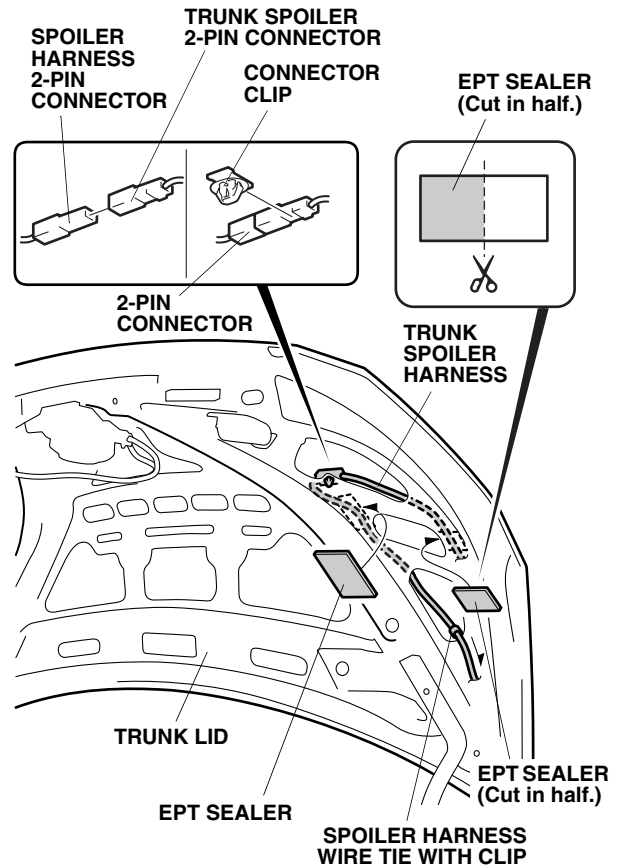

32. Route the spoiler harness along the trunk lid hinge and secure it with four spoiler harness wire ties with clip to the hinge holes.

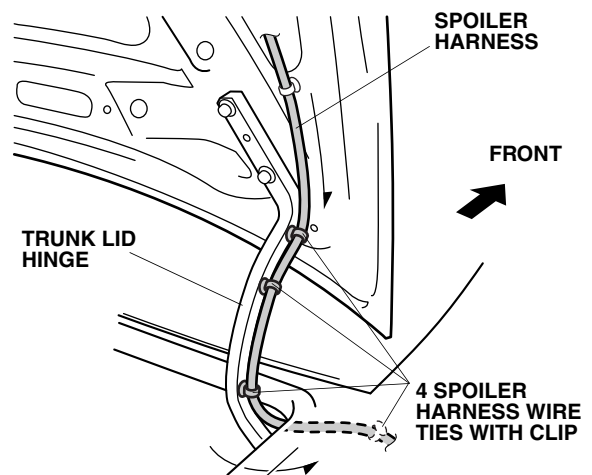

33. Route the spoiler harness and secure the two spoiler harness wire ties with clip to the vehicle panel holes.

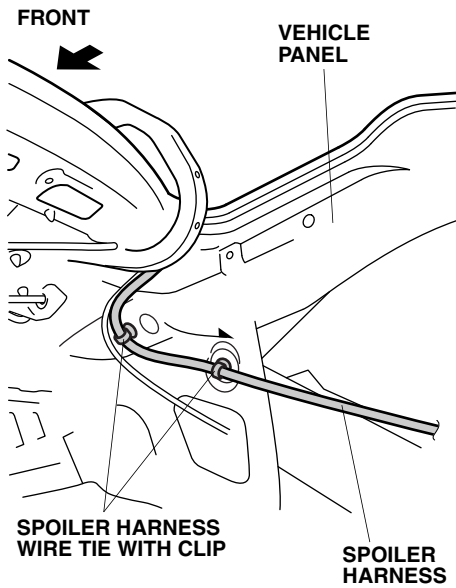

34. Disconnect the 4-pin connector from the right side brake light.
35. Connect the spoiler harness 4-pin connector to the right side brake light as shown.
36. Connect the vehicle harness 4-pin connector to the spoiler harness 4-pin connector as shown.

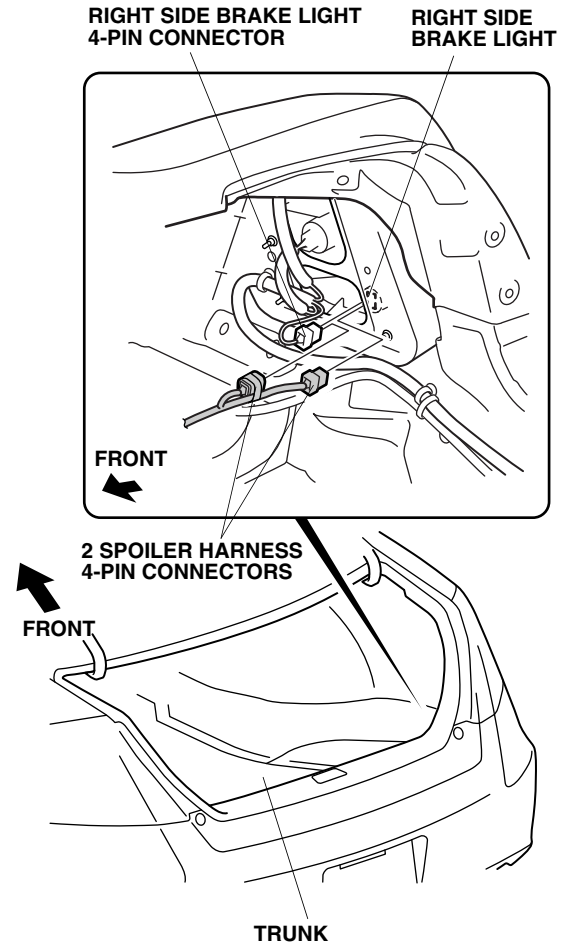

37. Secure the spoiler harness to the vehicle harness with one wire tie as shown.
38. Secure the spoiler harness 4-pin connector with one wire tie as shown.

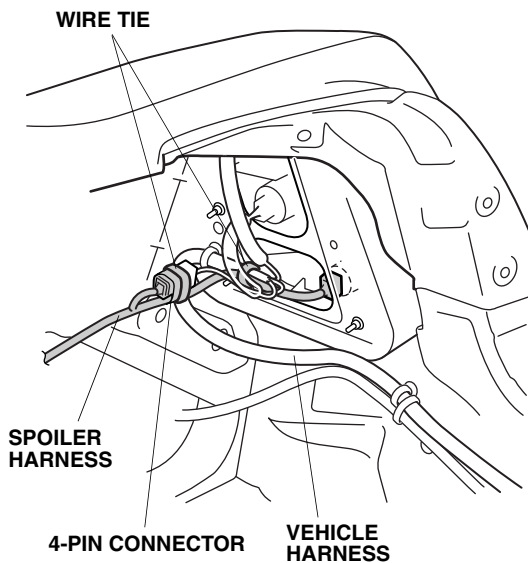

39. Disconnect the vehicle 2-pin connector from the high-mount brake light.
40. Remove the socket from the high-mount brake light by turning it counterclockwise, and then remove the bulb from the socket.
41. Reinstall the socket to the high-mount brake light, and connect the vehicle 2-pin connector to the high-mount brake light.

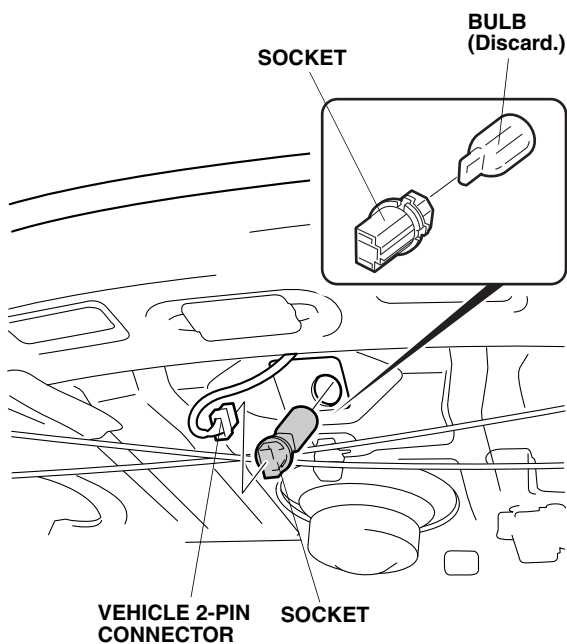

42. Open the trunk lid, and make sure the trunk lid stays open on its own. If it won't, adjust the trunk springs to the second position.
43. Check that all wire harnesses are routed properly and all connectors are plugged in.
44. Reconnect the negative cable to the battery.
45. Enter the customer's radio and navigation system (if equipped) anti-theft codes, and reset the radio station presets.
46. Reset the clock.
47. Press the brake pedal, and check that the spoiler brake light comes on.
48. Reinstall all removed parts.